

VIOFO

# USER MANUAL

## Dash Cam Battery Pack (BP100)

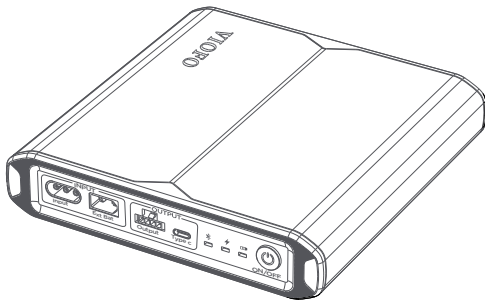

Copyright©2025 VIOFO Ltd. All Rights Reserved.

## About VIOFO Dash Cam Battery Pack BP100

The VIOFO BP100 Battery is designed to power your dash cam in Parking Mode for extended periods of time without using your vehicle's battery.

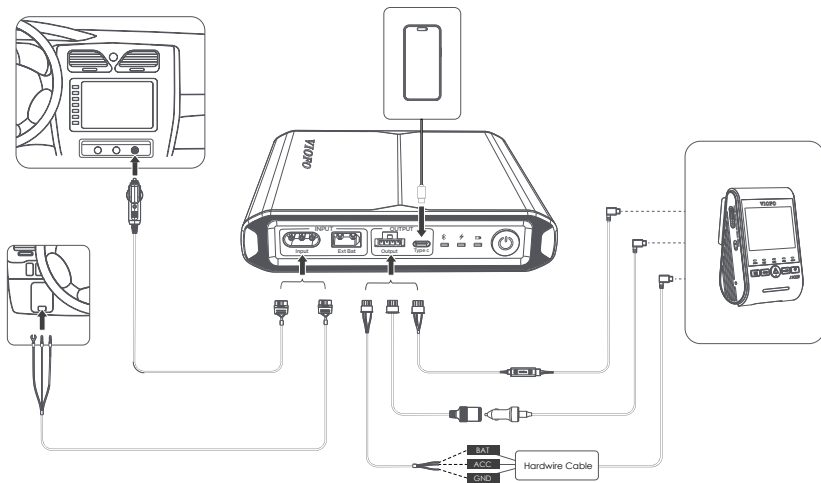



## Precautions

Please read this user manual carefully before using the product.

### **Safety information**

---

Please comply with the following safety information to safely use this product. Incorrect use of the Dash Cam Battery may lead to degradation of product performance, or cause overheating, ignition, explosion, etc., and even result in injury or property damage.

- Familiarize yourself with the user manual before using the product.
- Use the product exclusively to power dash cams.
- Use only original VIOFO cables provided with the product when installing it.
- Keep the product away from water or other liquids, and do not use it in a damp environment.
- Do not expose the product to direct sunlight or high temperatures.
- Do not place the product in a microwave or a high-pressure environment.
- Do not use the product in electrostatic or electromagnetic environments as it may affect the battery protection circuit.
- Keep the connection terminals of the charging and output cables of the battery out of contact with metal objects.
- Do not disassemble, repair or modify the product by yourself.

- Do not crush, puncture, or expose the product to physical impacts.
- If the battery swells up, immediately discontinue using the product and contact customer support for assistance.
- If the battery emits an unusual odor during use, immediately stop using the product and contact customer support for assistance.
- Keep the product out of reach of children and pets.

### **Battery pack disposal**

---

- Please dispose of all electronic products separately at designated collection facilities as required by the government or local authorities. Contact your local authorities for information on disposal and recycling options in your area.
- Do not incinerate battery or expose it to fire. Exposure to excessive heat may result in fire or explosion.

# Table of Contents

<b>1. Package Contents</b> .....	01	<b>8. Expansion Battery</b> .....	20
Standard Items		<b>9. Customer Service</b> .....	22
Optional Accessories (Sold Separately)		<b>10. Notice</b> .....	23
<b>2. Product Overview</b> .....	03		
<b>3. LED Indicators</b> .....	04		
<b>4. Product Specifications</b> .....	05		
<b>5. Product Features</b> .....	06		
<b>6. Installation</b> .....	08		
Via Cigarette Lighter Plug Power Cable			
Via Hardwiring Power Cable			
Install the Battery Pack			
Connect the Dash Cam			
<b>7. Battery APP Guide</b> .....	16		
Connect Battery APP			
APP Layout Overview			

## Package Contents

### Standard Items

---



Battery Pack



Hardwiring Power  
Cable (3M)



Cigarette Lighter  
Plug Power Cable (2M)



Hardwire Cable  
Adapter (2M)



Cigarette Lighter  
Output Cable (0.3M)



Hardwire Output Cable  
(Type-C) (4M)

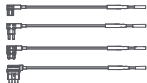

Fuse Holder  
(4 types)



Fuse  
(4 types)



Velcro Tapes

## Optional Accessories (Sold Separately)

---

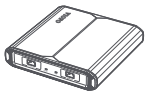

EP100  
Expansion Battery

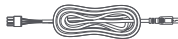

Hardwire Output Cable  
Mini-USB Connector (3M)

### **Note:**

- The EP100 includes a power cable enabling connection with BP100 to increase capacity.
- The Hardwire Output Cable Mini-USB Connector is compatible with VIOFO A119 V3, A129 Plus, and A129 Pro dashcams.

## Product Overview

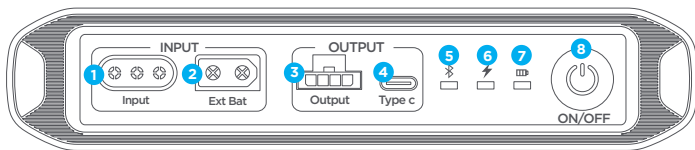

- 1 Input**  
Charging port for power cable connection

- 2 Ext Bat**  
Port for expansion battery

- 3 Output**  
Port for powering a dash cam  
(supports parking mode)

- 4 Type c**  
Port for powering a dash cam (parking mode  
not supported) / charging a mobile phone









- 5**   
Bluetooth status

- 6**   
Charging status

- 7**   
Battery status

- 8** ON/OFF  
Power on / Power off

## LED Indicators

LED	Led Status	Behavior
	Blue light flashes	Bluetooth not connected
	Blue light is constantly on	Bluetooth connected
	Red light flashes	Charging
	Red light is constantly on	Discharging
	Green light is constantly on	Battery level 80%-100%
	Yellow light is constantly on	Battery level 21%-79%
	Red light is constantly on	Battery level 5%-20%
	Red light flashes	Battery level below 5%

## Product Specifications

<b>Input Power</b>	Cigarette lighter cable    11.8V~28V 6A Max Hardwiring cable            11.8V~28V 11A Max
<b>Output Power</b>	Dash cam port                11.8V ~ 14.2V 3A Type-C port                    5V 3A
<b>Charging Time</b>	Cigarette lighter cable: Around 100 minutes Hardwiring cable: Within 70 minutes
<b>Voltage &amp; Capacity &amp; Energy</b>	12.8V / 7650mAh / 98Wh
<b>Available Hours</b>	Approx. 32 hours (based on consuming 3W)
<b>Dimension &amp; Weight</b>	171 mm (L) x 171 mm (W) x 35 mm (H) / 1.22 kg
<b>Battery Type</b>	LiFePO4
<b>Charging Operating Temperature</b>	0°C ~ 50°C (32°F ~ 122°F)

## Product Features

- Connect the VIOFO hardwire cable to enable parking mode for the dashcam.
- The hardwire output cable can be used as a replacement for the original hardwire cable.
- Supports two installation methods:  
Cigarette lighter installation: Plug the cigarette lighter plug power cable into your vehicle's cigarette lighter;  
Fuse box installation: Connect the hardwiring power cable into the vehicle's fuse box.
- After around 100 minutes of charging via the vehicle's cigarette lighter or within 70 minutes via the fuse box, the battery pack can power the dashcam for up to 32 hours (based on a 3W dashcam usage).
- Compatible with both passenger car (12V), and heavy duty commercial (24V) electrical systems.
- During driving the vehicle charges the BP100, and powers the dashcam simultaneously, (Pass-Through Charging).
- When the vehicle is turned off, the BP100 continues to power the dashcam.
- With built-in Bluetooth, users can check the battery status in real-time through the smartphone app.

- The built-in Battery Management System (BMS) controls current, voltage, balance, and prevents overcharge, overdischarge, overcurrent of the BP100.
- The battery capacity can be increased by connecting expansion batteries. It is recommended to connect no more than two expansion batteries.
- The app will pop up a warning alert if BP100 internal temperature reaches 50°C (122°F), and will automatically shut down if BP100 internal temperature exceeds 70°C (158°F) to prevent overheating.
- Battery cycle life: Rated for 1,500 charge/discharge cycles before the battery capacity drops to 80% of the original capacity.
- The Type-C output port of the battery allows you to simultaneously charge the mobile phone while powering the dash cam.

## Installation

### Via Cigarette Lighter Plug Power Cable

1. Switch off the battery pack before installation.
2. Plug the cigarette lighter plug power cable into the Input port of the battery pack, and connect the other end of the power cable to the vehicle's cigarette lighter socket.

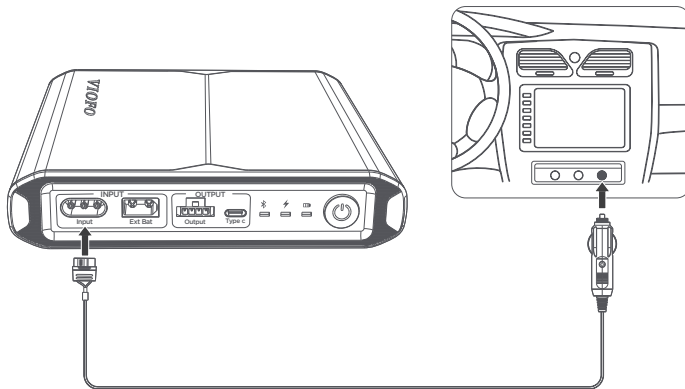

## Via Hardwiring Power Cable

---

1. Switch off the battery pack before installation.
2. Plug the hardwiring power cable into the Input port of the battery pack.

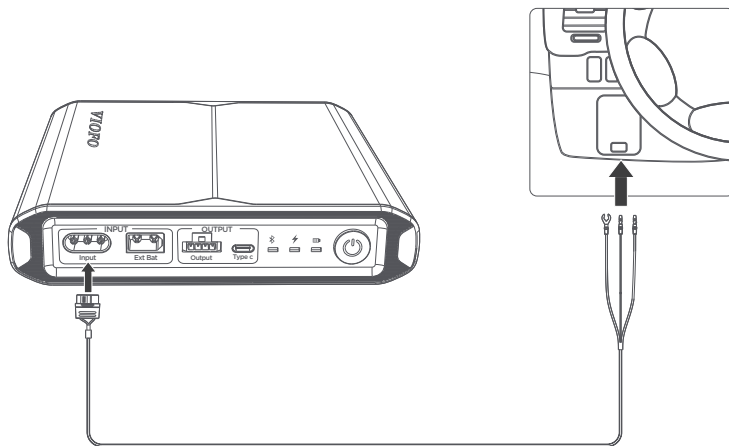

### 3. Locate your Fuse Box.

Fuse boxes and fuse types vary not only between car models, but also on year and variant. Check the Car Manual to find the fuse box location and confirm the fuse type.

### 4. Identify which fuse is ACC & Battery.

- Battery Wire (RED)

To identify a fuse for the battery connection, turn the ignition switch to the lock position. Look for a fuse that is live (allows electricity to flow) even when the ignition switch is in the off position. You can identify the fuse by applying a fuse/circuit/voltage test device when the engine is off. Place the tip of the tester on the exposed metal part of the fuse.

- ACC Wire (YELLOW)

To identify a fuse for the ACC connection, turn the ignition switch to the ACC (Accessory) position. Look for a fuse that is live when the ignition switch is in the ACC position but off when the ignition switch is in the off position.

### 5. Locate a Ground point.

To identify a suitable ground point, use circuit tester in continuity mode. Locate a screw with direct connection to the vehicle body and check for a good continuity reading between the screw and the vehicle body, this should be  $< 0.1$  ohm.

6. Connect an Add-A-Fuse kit to the hardwiring power cable.

Use an Add-A-Fuse kit for a clean installation. Once the fuse slot and fuse type required for the hardwiring power cable are determined, a suitable Add-A-Fuse kit can be crimped to the hardwiring power cable ACC and BAT connections. The crimp can be made successfully using either a standard crimp tool, or using standard needle nose pliers.

7. Connect the fuses.

Yellow (ACC) accessory power supply — Connect to a fuse that turns on / off with the engine.

Red (Battery) constant power supply — Connect to a fuse that is always powered, the connection must be made after passing through the fuse.

Black (Ground) connection — Place the spade connector under the head of a ground point screw or bolt ensuring a clean electrical contact and tighten the screw to secure.

## Install the Battery Pack

---

Secure the battery pack at a suitable location inside the car using the Velcro tapes. We recommend installing the battery in the car's glove compartment.

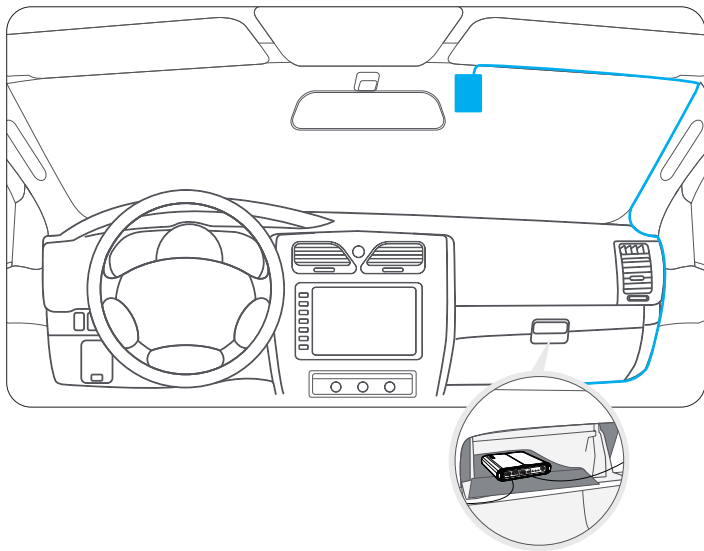

## Connect the Dash Cam

### ■ Via Cigarette Lighter Output Cable

1. Plug the cigarette lighter output cable into the Output port of the battery pack.
2. Connect your dashcam's car charger adapter to the cigarette lighter socket of the cigarette lighter output cable.

**Note:** This connection method does not support parking mode.

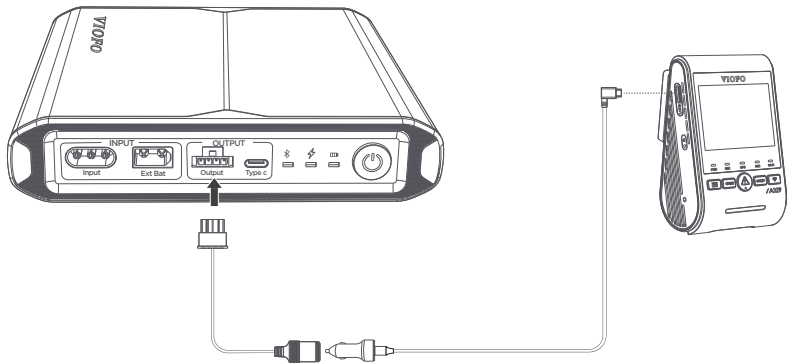

## ■ Via Hardwire Cable Adapter

1. Plug the hardwire cable adapter into the Output port of the battery pack.
2. Connect ACC, ground (GND), and battery (BAT) wires separately to the corresponding wires of the VIOFO hardwire cable (sold separately).
3. Connect the other end of the hardwire cable to the dashcam. When the car is turned off, the battery pack continues to power the dashcam, and enables parking mode.

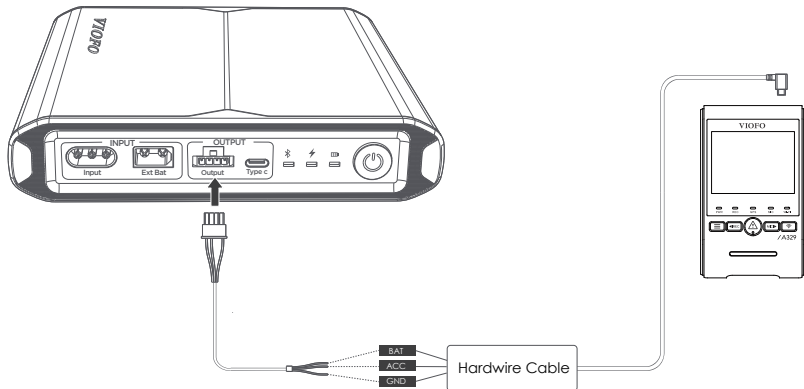

## ■ Via Hardwire Output Cable

1. Plug the Hardwire Output cable into the Output port of the battery pack.
2. Connect the other end of the Hardwire Output cable to your dashcam.

**Note:** This Hardwire Output cable can replace the original hardwire cable for enabling the parking mode for the dashcam.

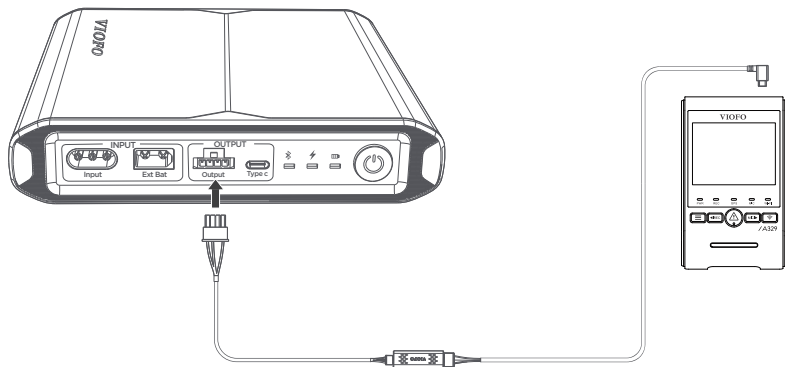

## Battery APP Guide

### Connect Battery APP

---

The VIOFO battery app allows you to check the battery status in real-time.

- **Android Device**

Android users can download the app from Google Play.

- **IOS Device**

IOS users can download the app from the App store.



Download on the  
**App Store**



GET IT ON  
**Google Play**

## ■ Connect via Bluetooth

1. Turn on the battery pack.
2. Turn on your smartphone's Bluetooth.
3. Open the VIOFO Battery App. Click "Add a device" to search your battery.
4. Click the "BP100\_XXXX" button on the screen to connect.

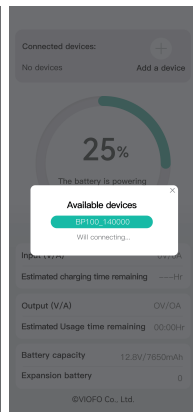
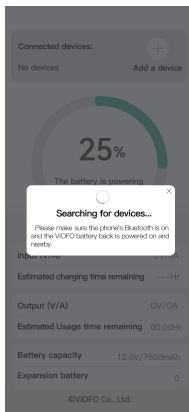
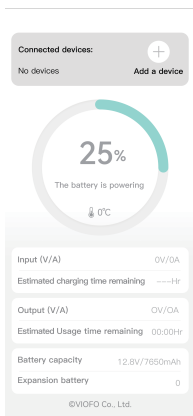

## APP Layout Overview

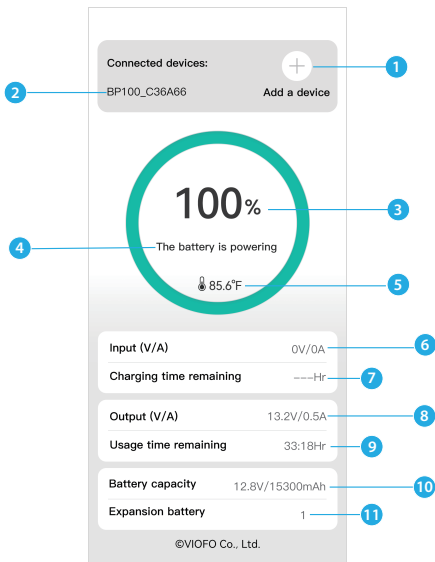

1 - Add Device

2 - Battery Bluetooth ID

3 - Battery Level

4 - Battery Charge/Discharge State

5 - Battery Temperature

6 - Input Voltage and Current to Battery

7 - Estimated Time for Full Charge

8 - Output Voltage and Current from Battery

9 - Estimated Usage Time

10 - Battery Capacity

11 - Number of Expansion Battery  
(manually set by the user)

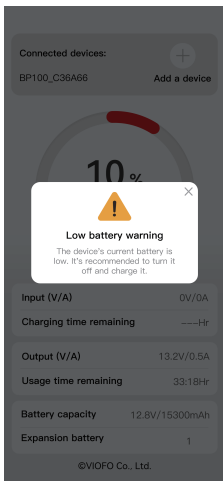

### Low Battery Warning:

This warning alert will be displayed if the battery level drops below 10%.

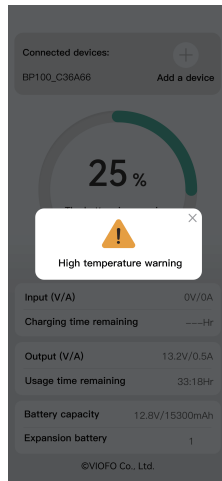

### High Temperature Warning:

This warning alert will be displayed if BP100 internal temperature reaches 50°C (122°F).

## Expansion Battery

The expansion battery EP100 is designed to easily add the capacity to the BP100 dash cam battery pack.

### Install the Expansion Battery

---

1. Connect the Ext Bat port of the battery BP100 to the IN/OUT port of the expansion battery using the cable provided with the EP100.
2. After adding optional EP100, please enter number of expansion batteries to obtain total available capacity.

**Note:** If one EP100 is connected, the BP100 can automatically detect it. If two or more are connected, the number of expansion batteries must be entered manually to calculate the total capacity.

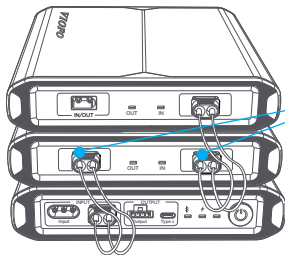

The connecting cable can be plugged into either port on the expansion battery.

By adding an expansion battery (7650mAh), you can easily double the battery runtime. Please note that the charging time will also increase accordingly.

## LED Indicators

---

LED	Led Status	Behavior
IN	Red light is constantly on	Charging
OUT	Green light is constantly on	Discharging

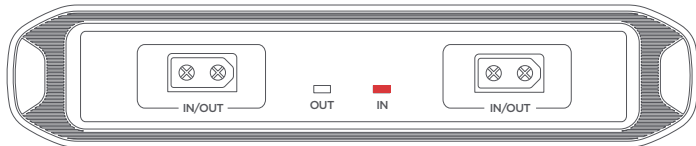

## Customer Service

Thanks for choosing VIOFO!

From the date of purchase on, this product is warranted for 18 months.

VIOFO offers lifetime technical support for all our users. We are committed to making sure that you are 100% satisfied with our products and services.

### How to Contact Us?



Submit a ticket at [viofo.com/support](https://viofo.com/support)



Live chat box at [www.viofo.com](https://www.viofo.com)



[support@viofo.com](mailto:support@viofo.com)



[www.facebook.com/viofo](https://www.facebook.com/viofo)



+1 323 505 9898 (USA)  
+1 323 609 9898 (Global)



Mon-Fri 9am-6pm



Scan the QR code to submit a ticket

## Notice

This device complies with part 15 of the FCC Rules. Operation is subject to the following two conditions: (1) This device may not cause harmful interference, and (2) this device must accept any interference received, including interference that may cause undesired operation.

FCC warning:

Any changes or modifications not expressly approved by the party responsible for compliance could void the user's authority to operate the equipment.

**Note:** This equipment has been tested and found to comply with the limits for a Class B digital device, pursuant to part 15 of the FCC Rules. These limits are designed to provide reasonable protection against harmful interference in a residential installation. This equipment generates uses and can radiate radio frequency energy and, if not installed and used in accordance with the instructions, may cause harmful interference to radio communications. However, there is no guarantee that interference will not occur in a particular installation. If this equipment does cause harmful interference to radio or television reception, which can be determined by turning the equipment off and on, the user is encouraged to try to correct the interference by one or more of the following measures:

- Reorient or relocate the receiving antenna.
- Increase the separation between the equipment and receiver.

-Connect the equipment into an outlet on a circuit different from that to which the receiver is connected.

-Consult the dealer or an experienced radio/TV technician for help.

The device has been evaluated to meet general RF exposure requirement. The device can be used in portable exposure condition without restriction.



Scan to Access User Guide Videos



Scan to Access User Manual

V25.11.18