

AUTO EASE

POWER LIFTGATE MANUAL



For
Toyota Corolla Cross

This power lift gate kit for Toyota Corolla Cross support automatic trunk open/close control by using 1) original key fob 2) dashboard button 3) rear door button 4) Foot sensor – optional









NOTICE

1. Check parts & quantity in the accessories table. Must use the brackets/screws provided by us if not stated.
2. Shut down engine before installation. Product must be installed by qualified installers.
3. Strut assembly contains high pressure part, self-disassembling the poles is prohibited.
4. Make protections of the car dashboard, plastic, and metal surface, in case scratches during installation.
5. Secure all the cables/wires in the car in case loose contact while driving.
6. The installation will take 2-3 hours, please follow the manual patiently.



ATTENTION:

- i. The liftgate is designed for standard factory tailgate
- ii. Bench-test is forbidden, the lift gate must be installed in car and test directly
- iii. Do not insert power plug to ECU control box until all the installation procedure is completed
- iv. Keep tailgate open when installation is completed, make sure latch modular is released
- v. Initialize system after installation - manually lift tailgate to a proper height, keep pressing our rear button until hear a beep, then click our rear button to close, when tailgate is fully closed and you hear a beep, it means the system is initialized and ready for use.

PART LIST

			
Power Struts x2	Control Box x1	Motorized Latch x1	Power Cable x1
			
Lock Assembly x1	Front Button x1	Rear Button x1	Bracket & Screw x2

TOOLS (not included)

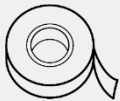
			
Trim Remover x1	Spanner x1	Cable Route Puller x1	Electric Tape x1

REMARK: Pictures for reference only, they may look different or not reflect actual product while products being updated time to time. Autoease keep the right to update appearance & design without notifications.

SCHEME

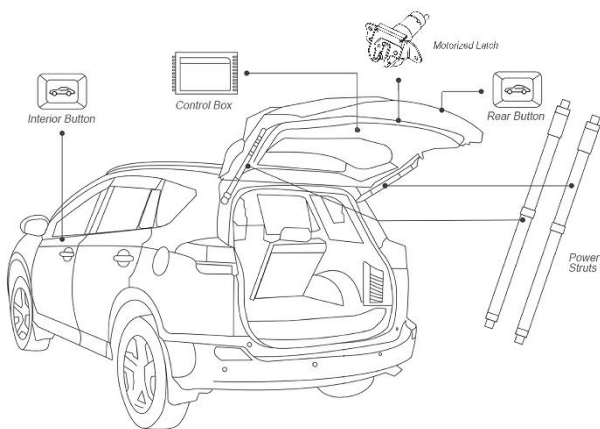

CONTROL BOX

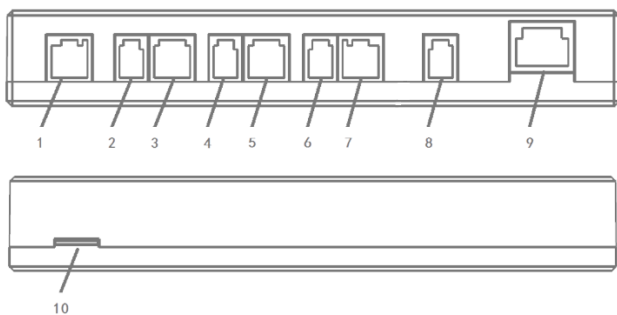

- 1 Power
- 2/3 Left Strut
- 4/5 Right Strut
- 6/7 Power Latch
- 8 Front Button
- 9 Lock Assembly
- 10 MicroSD Slot

INSTALLATION STEPS

1. Remove original hatch door panels with a plastic wrench



2. Loosen original gas spring clips by using a screwdriver, pull the gas spring out gently. You will need an assist to hold the door when removing the gas springs



3. Replace original car body bracket to ours, fix with our screws

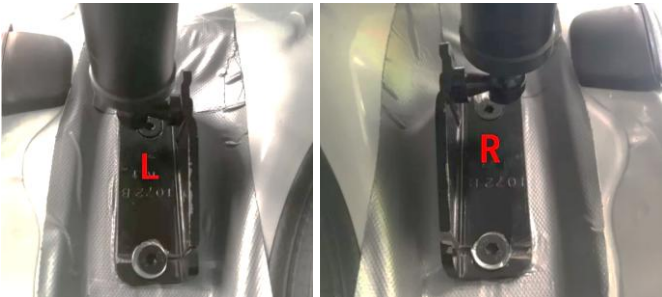

4. Use original door bracket to fix our install strut. Note strut cable at this end, drill a hole per picture to route strut cable



5. Replace original door latch to our power latch, fix with original screws



6. Route * power cable * unlock wire * front button cable to rear door (control box). Picture for reference



7. Ground our GND wire to a screw on rear door panel



8. Connect our lock harness to original lock connector



9. Locate original unlock wire for remote control, you can find it inside triangle panel at driver side

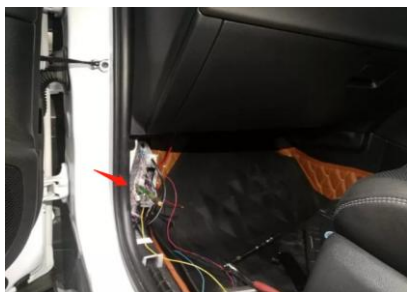

Connect our yellow wire to original green wire per picture



10. Replace original dash button holder to our front button



11. Locate original fuse box under driver's dashboard, remove original 20A or 30A fuse, insert our fuse power plug.

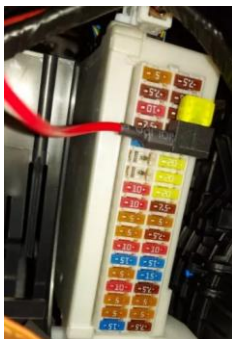
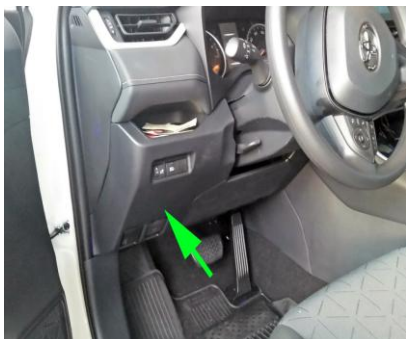

12. Install our rear button (picture for reference)



13. Insert all plugs to the control unit, leave power cable as the last one, you will hear a beep once power connected

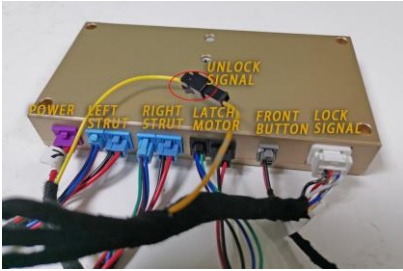

Place our control box on rear door panel, fix with a provided screw



14. Restore rear door panels, installation completed

Initialize system after installation - manually lift tailgate to a desired height(must be 10mm less than max height), keep on pressing our rear button around 3 seconds until a beep is heard, short click our rear button to close, when door is fully

closed and you hear a beep, it means the system is initialized and ready for use.

FREQUENTLY ASKED QUESTIONS

1. How to operate the liftgate?

There are four methods as below:

- 1) Use original remote – 3x unlock
- 2) Use our rear button – 1x
- 3) Use our front button – long press
- 4) Use foot sensor – Sold separately

2. How to setup tailgate height?

Manually lift door to a desired height, long press our rear button until you hear a beep, done.

3. Why there are two beeps when door closing?

- 1) two beep means anti-pinch, check if anything is preventing strut/door movement
- 2) inspect power supply, include positive 12-16v, negative connects, and fuse box

4. Tailgate cannot be closed to the end and not locked

- 1) slightly adjust latch hook position
- 2) reverse left and right strut plugs in control box
- 3) check control box wiring
- 4) must using our screws in the box
- 5) remove rubber lock buffer block in the latch

5. Tailgate can only open to half of the height

- 1) reverse left and right strut plugs in control box
- 2) reset tailgate height

6. Original remote/fob does not work

- 1) check our yellow wire connection to original unlock signal
- 2) check OBD connection if kit has a decoder box
- 3) adjust click rhythm
- 4) check OEM vehicle's system settings about unlock signal

7. Front button can open but not close the gate

- 1) check front button wires connection
- 2) check lock adapter (status) signal
- 3) update firmware